

## ILLUSTRATED PARTS BREAKDOWN

**PARTNER**

**12 HP, 42" MOWER DECK**

**LAWN TRACTOR**

**MODEL NUMBER 12-107H (P12H107A)**

**964 77 71-00**

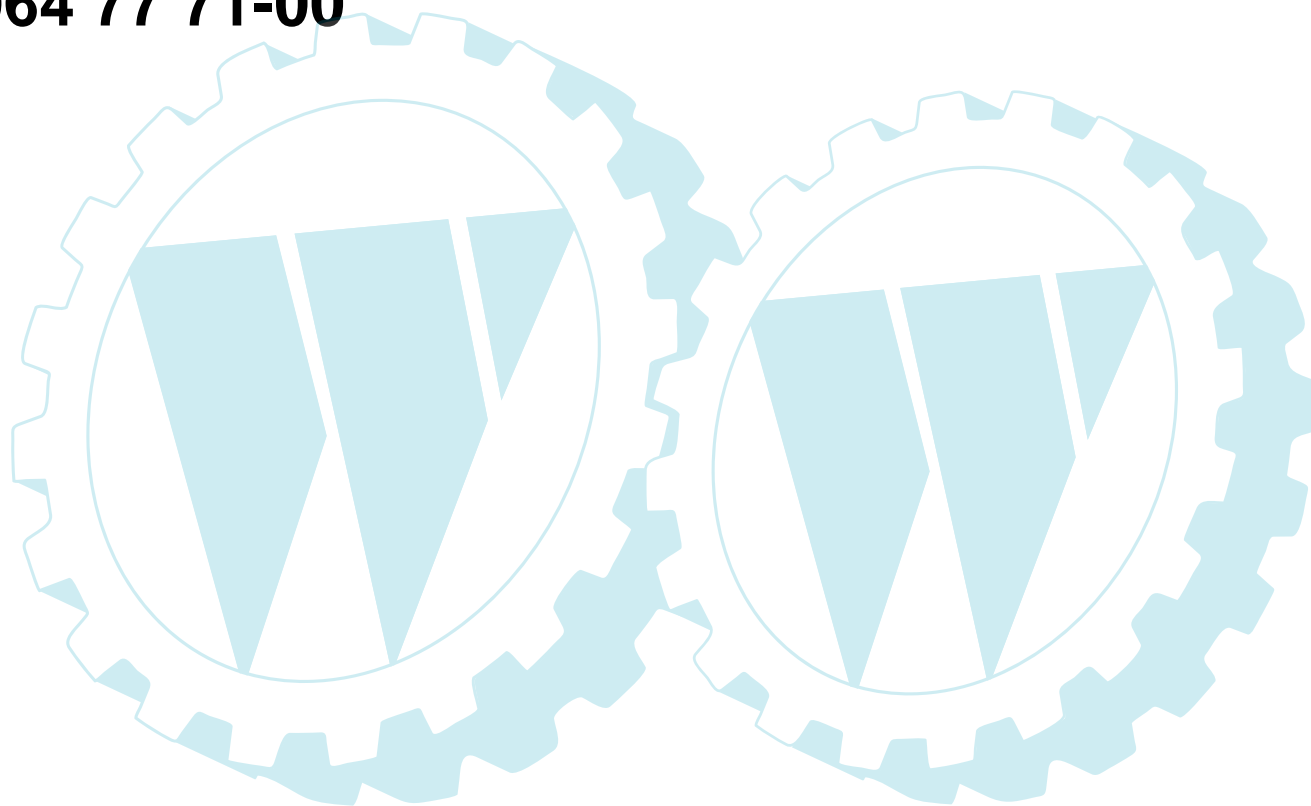

**TRACTOR- -MODEL NO. 12-107H (P12H107A), PRODUCT NO. 964 77 71-00  
SCHEMATIC**

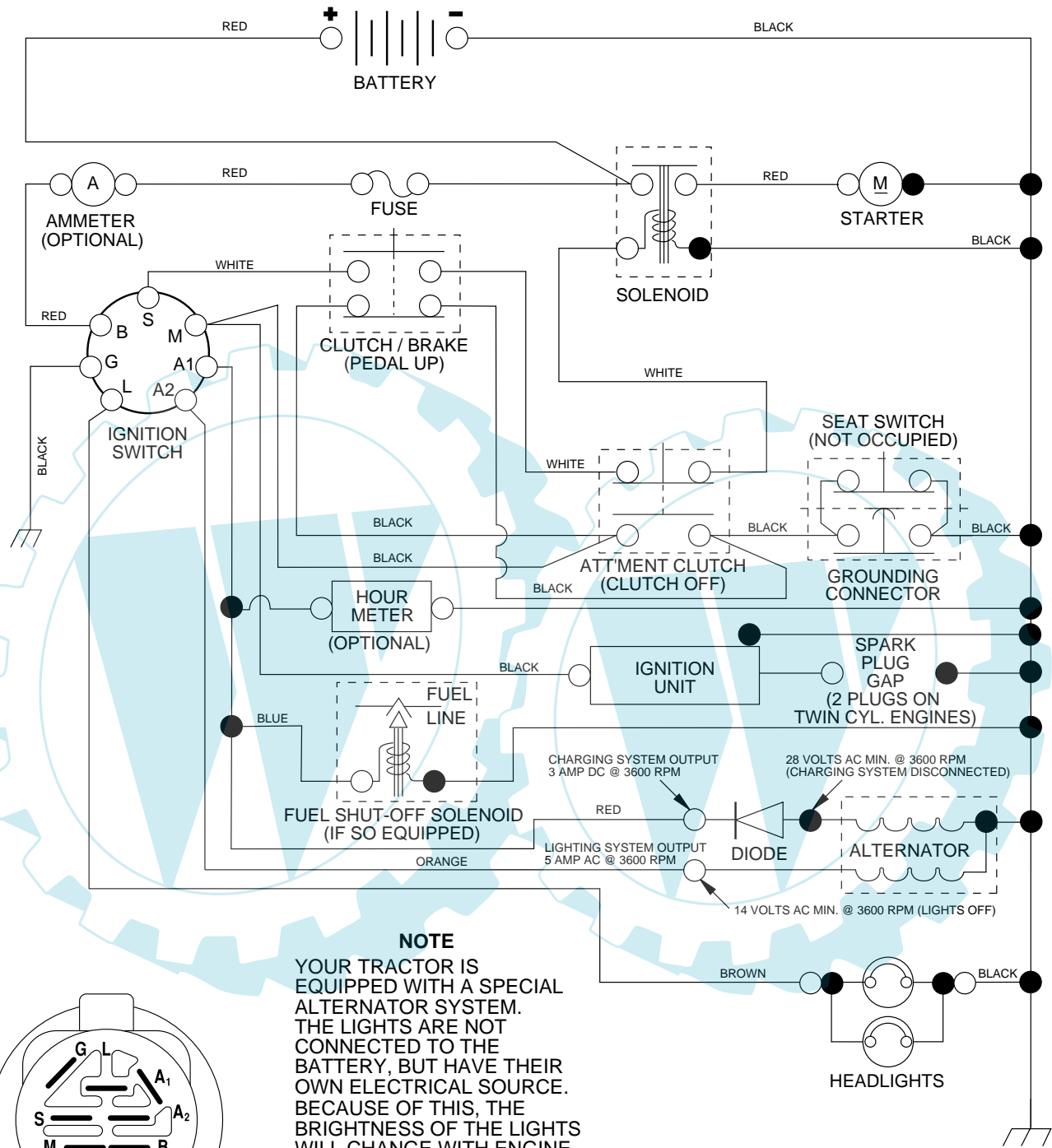

**NOTE**  
YOUR TRACTOR IS EQUIPPED WITH A SPECIAL ALTERNATOR SYSTEM. THE LIGHTS ARE NOT CONNECTED TO THE BATTERY, BUT HAVE THEIR OWN ELECTRICAL SOURCE. BECAUSE OF THIS, THE BRIGHTNESS OF THE LIGHTS WILL CHANGE WITH ENGINE SPEED. AT IDLE THE LIGHTS WILL DIM. AS THE ENGINE IS SPEEDED UP, THE LIGHTS WILL BECOME THEIR BRIGHTEST.

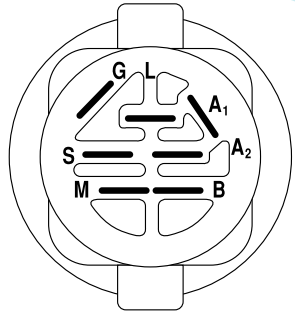

**IGNITION SWITCH**

| POSITION  | CIRCUIT    | "MAKE" |
|-----------|------------|--------|
| OFF       | M+G+A1     | NONE   |
| RUN/LIGHT | B+A1       | A2+L   |
| RUN       | B+A1       | NONE   |
| START     | B + S + A1 | NONE   |

**WIRING INSULATED CLIPS**

**NOTE:** IF WIRING INSULATED CLIPS WERE REMOVED FOR SERVICING OF UNIT, THEY SHOULD BE REPLACED TO PROPERLY SECURE YOUR WIRING.

NON-REMOVABLE CONNECTIONS

REMOVABLE CONNECTIONS

# REPAIR PARTS

TRACTOR- -MODEL NO. 12-107H (P12H107A), PRODUCT NO. 964 77 71-00  
ELECTRICAL

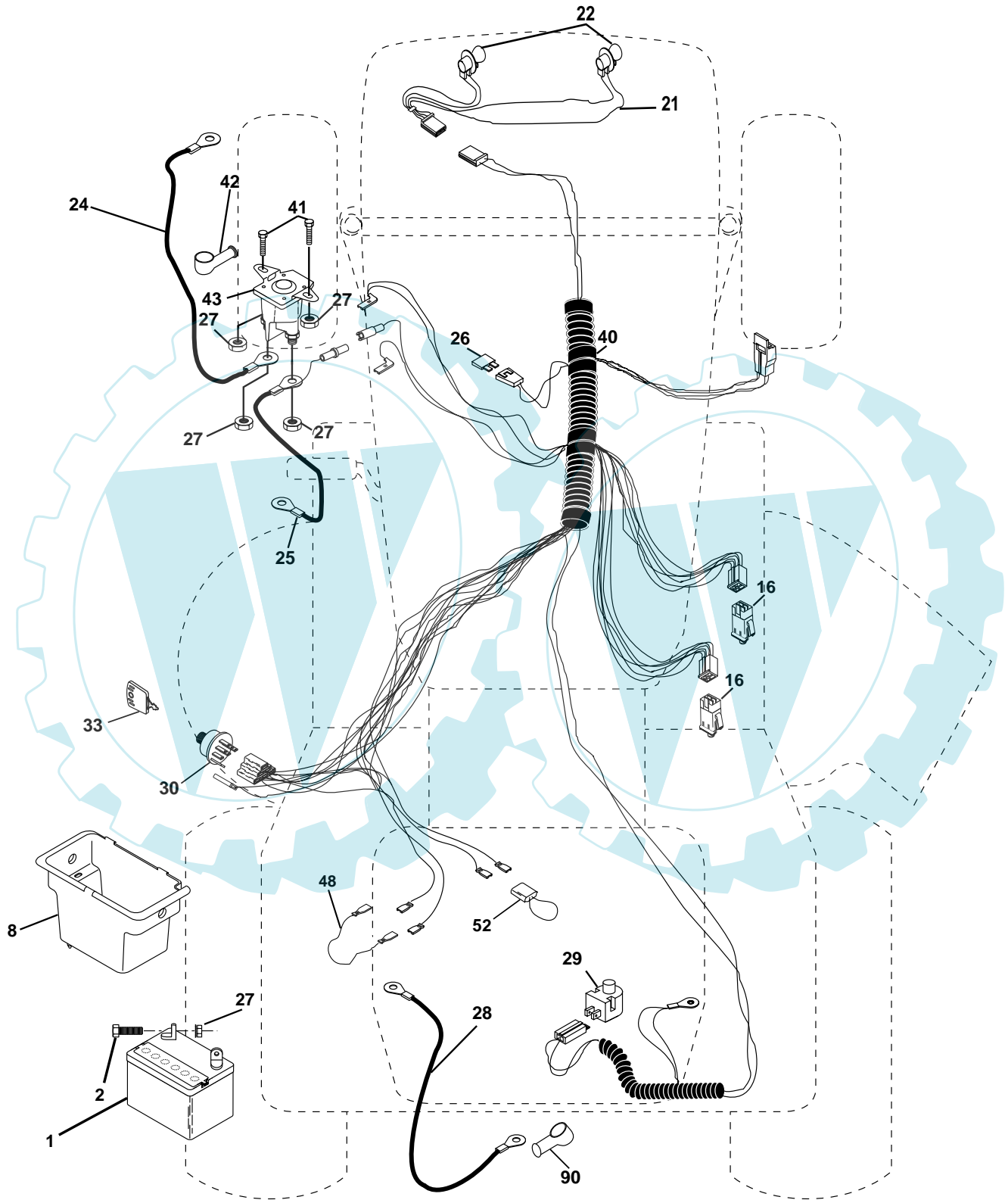

## REPAIR PARTS

TRACTOR- -MODEL NO. 12-107H (P12H107A), PRODUCT NO. 964 77 71-00  
ELECTRICAL

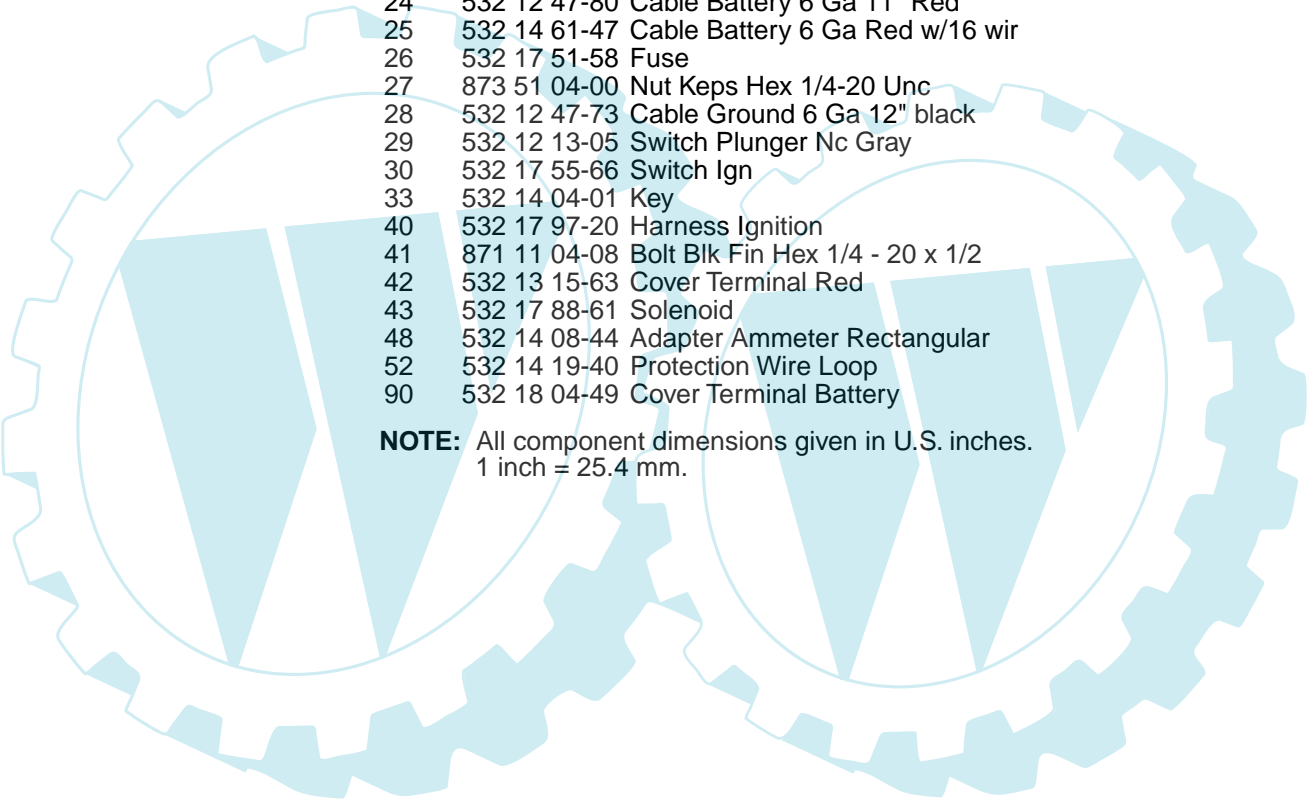

| KEY NO. | PART NO.     | DESCRIPTION                     |
|---------|--------------|---------------------------------|
| 1       | 532 16 34-65 | Battery                         |
| 2       | 874 76 04-12 | Bolt Hex Hd 1/4-20unc X 3/4     |
| 8       | 532 17 66-89 | Box Battery Fender              |
| 16      | 532 17 61-38 | Switch Interlock                |
| 21      | 532 18 37-59 | Harness Asm Light W/4152j       |
| 22      | 532 00 41-52 | Bulb Light #1156                |
| 24      | 532 12 47-80 | Cable Battery 6 Ga 11" Red      |
| 25      | 532 14 61-47 | Cable Battery 6 Ga Red w/16 wir |
| 26      | 532 17 51-58 | Fuse                            |
| 27      | 873 51 04-00 | Nut Keps Hex 1/4-20 Unc         |
| 28      | 532 12 47-73 | Cable Ground 6 Ga 12" black     |
| 29      | 532 12 13-05 | Switch Plunger Nc Gray          |
| 30      | 532 17 55-66 | Switch Ign                      |
| 33      | 532 14 04-01 | Key                             |
| 40      | 532 17 97-20 | Harness Ignition                |
| 41      | 871 11 04-08 | Bolt Blk Fin Hex 1/4 - 20 x 1/2 |
| 42      | 532 13 15-63 | Cover Terminal Red              |
| 43      | 532 17 88-61 | Solenoid                        |
| 48      | 532 14 08-44 | Adapter Ammeter Rectangular     |
| 52      | 532 14 19-40 | Protection Wire Loop            |
| 90      | 532 18 04-49 | Cover Terminal Battery          |

**NOTE:** All component dimensions given in U.S. inches.  
1 inch = 25.4 mm.

# REPAIR PARTS

TRACTOR- -MODEL NO. 12-107H (P12H107A), PRODUCT NO. 964 77 71-00  
CHASSIS AND ENCLOSURES

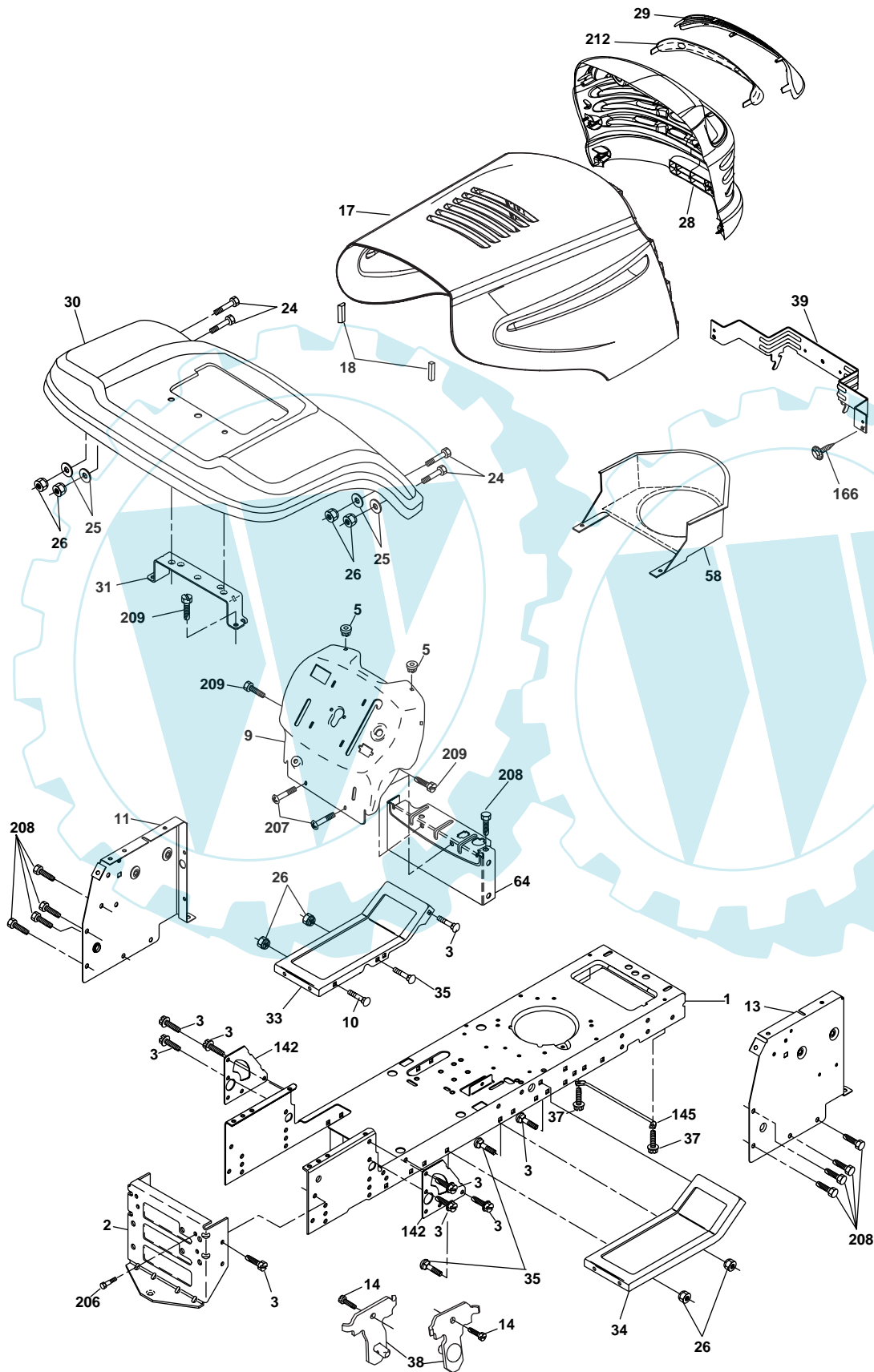

## REPAIR PARTS

TRACTOR- -MODEL NO. 12-107H (P12H107A), PRODUCT NO. 964 77 71-00  
CHASSIS AND ENCLOSURES

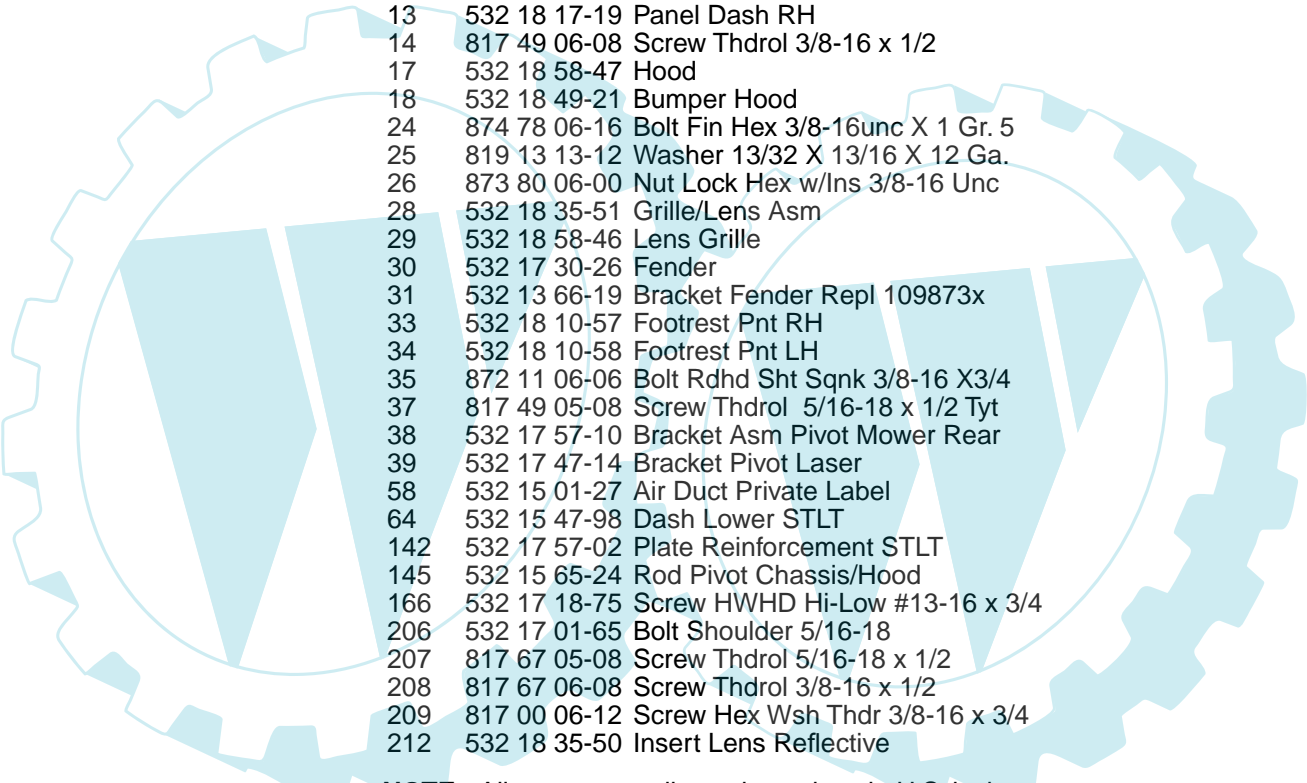

| KEY NO. | PART NO.     | DESCRIPTION                      |
|---------|--------------|----------------------------------|
| 1       | 532 17 46-19 | Chassis                          |
| 2       | 532 17 65-54 | Drawbar                          |
| 3       | 817 06 06-12 | Screw 3/8-16 x .75               |
| 5       | 532 15 52-72 | Bumper Hood Dash                 |
| 9       | 532 18 52-74 | Dash                             |
| 10      | 872 14 06-08 | Bolt Rdhd Sqnk 3/8-16unc X 1     |
| 11      | 532 17 49-96 | Panel Dash LH                    |
| 13      | 532 18 17-19 | Panel Dash RH                    |
| 14      | 817 49 06-08 | Screw Thdrol 3/8-16 x 1/2        |
| 17      | 532 18 58-47 | Hood                             |
| 18      | 532 18 49-21 | Bumper Hood                      |
| 24      | 874 78 06-16 | Bolt Fin Hex 3/8-16unc X 1 Gr. 5 |
| 25      | 819 13 13-12 | Washer 13/32 X 13/16 X 12 Ga.    |
| 26      | 873 80 06-00 | Nut Lock Hex w/Ins 3/8-16 Unc    |
| 28      | 532 18 35-51 | Grille/Lens Asm                  |
| 29      | 532 18 58-46 | Lens Grille                      |
| 30      | 532 17 30-26 | Fender                           |
| 31      | 532 13 66-19 | Bracket Fender Repl 109873x      |
| 33      | 532 18 10-57 | Footrest Pnt RH                  |
| 34      | 532 18 10-58 | Footrest Pnt LH                  |
| 35      | 872 11 06-06 | Bolt Rdhd Sht Sqnk 3/8-16 X3/4   |
| 37      | 817 49 05-08 | Screw Thdrol 5/16-18 x 1/2 Tyt   |
| 38      | 532 17 57-10 | Bracket Asm Pivot Mower Rear     |
| 39      | 532 17 47-14 | Bracket Pivot Laser              |
| 58      | 532 15 01-27 | Air Duct Private Label           |
| 64      | 532 15 47-98 | Dash Lower STLT                  |
| 142     | 532 17 57-02 | Plate Reinforcement STLT         |
| 145     | 532 15 65-24 | Rod Pivot Chassis/Hood           |
| 166     | 532 17 18-75 | Screw HWHD Hi-Low #13-16 x 3/4   |
| 206     | 532 17 01-65 | Bolt Shoulder 5/16-18            |
| 207     | 817 67 05-08 | Screw Thdrol 5/16-18 x 1/2       |
| 208     | 817 67 06-08 | Screw Thdrol 3/8-16 x 1/2        |
| 209     | 817 00 06-12 | Screw Hex Wsh Thdr 3/8-16 x 3/4  |
| 212     | 532 18 35-50 | Insert Lens Reflective           |

**NOTE:** All component dimensions given in U.S. inches.  
1 inch = 25.4 mm.

# REPAIR PARTS

TRACTOR- -MODEL NO. 12-107H (P12H107A), PRODUCT NO. 964 77 71-00  
DRIVE

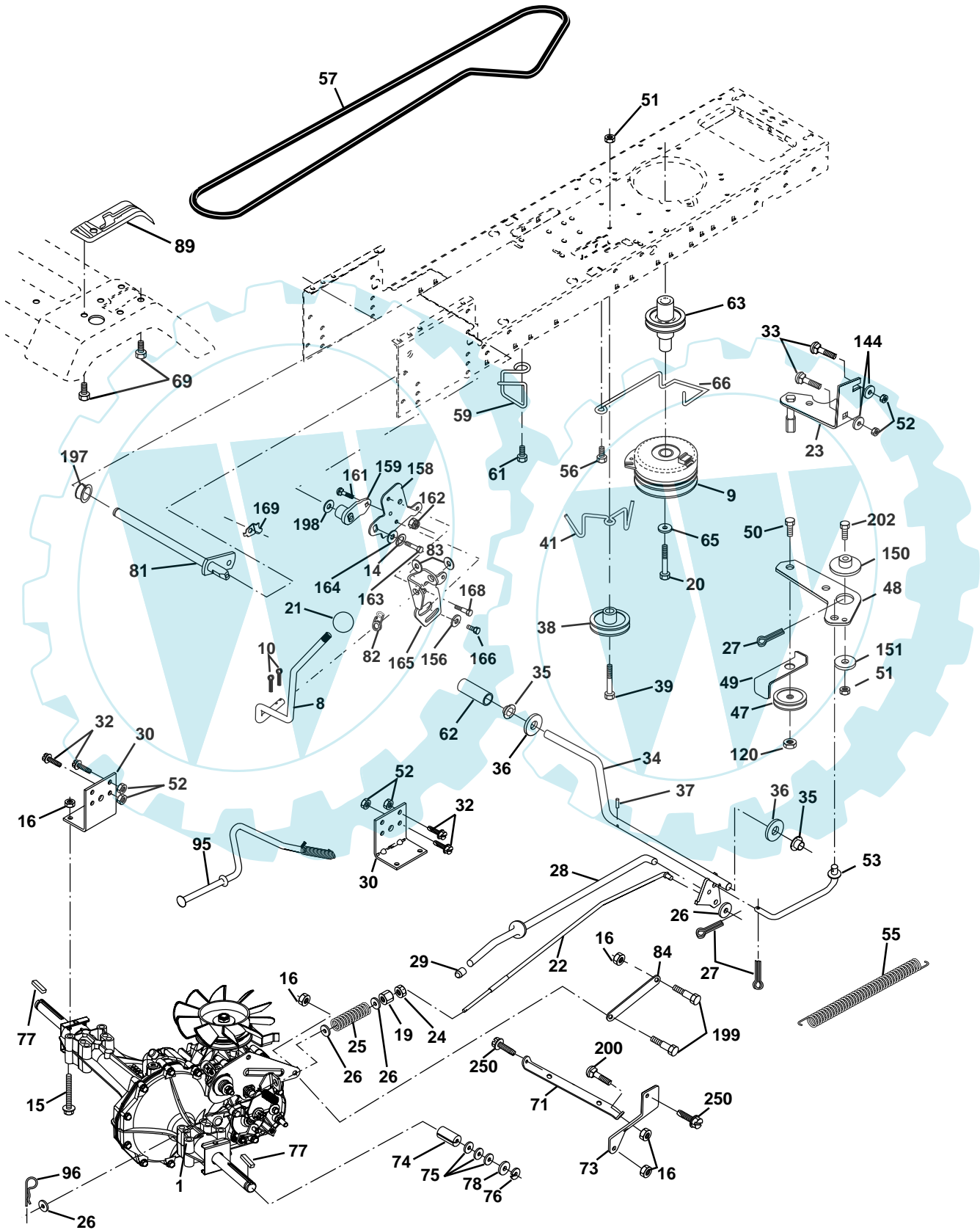

# REPAIR PARTS

**TRACTOR- -MODEL NO. 12-107H (P12H107A), PRODUCT NO. 964 77 71-00**  
**DRIVE**

| KEY NO. | PART NO.     | DESCRIPTION  | KEY NO. | PART NO.     | DESCRIPTION                      |
|---------|--------------|--|---------|--------------|----------------------------------|
| 1       | -----        | Transmission Hydro 322-0510<br>(Order parts from transaxle manufacturer) | 71      | 532 16 91-83 | Strap, Torque, Lh                |
| 8       | 532 16 56-19 | Rod, Shift   | 73      | 532 16 91-82 | Strap, Torque, Rh                |
| 10      | 876 02 04-16 | Pin, Cotter 1/8 x 1  | 74      | 532 13 70-57 | Spacer, Axle                     |
| 14      | 810 04 04-00 | Washer Lock Hvy Helical  | 75      | 532 12 17-49 | Washer 25/32 x 1-1/4 x 16 Ga.    |
| 15      | 874 49 05-44 | Bolt Hex FLGHD 5/16-18 Gr. 5   | 76      | 812 00 00-01 | Ring, E                          |
| 16      | 873 80 05-00 | Nut, Lock Hex w/Ins 5/16-18 UNC  | 77      | 532 12 35-83 | Key, Square                      |
| 19      | 873 80 06-00 | Nut, Lock Hex w/Wsh 3/8-16 UNC   | 78      | 532 12 17-48 | Washer 25/32 x 1-5/8 x 16 Ga.    |
| 21      | 532 10 69-33 | Knob Rd. 1/2-13 Plstc. Thds. Blk.  | 81      | 532 16 55-96 | Asm, Shaft Cross                 |
| 22      | 532 16 94-98 | Rod, Brake   | 82      | 532 12 37-82 | Spring, Torsion                  |
| 24      | 873 35 06-00 | Nut  | 83      | 819 17 12-16 | Washer 17/32 x 3/4 x 16 Ga.      |
| 25      | 532 10 68-88 | Spring, Rod, Brake   | 84      | 532 16 98-43 | Link, Transaxle                  |
| 26      | 819 13 13-16 | Washer 13/32 x 13/16 x 16 Ga.  | 89      | 532 17 30-29 | Console, Shift                   |
| 27      | 876 02 04-12 | Pin, Cotter 1/8 x 3/4  | 95      | 532 17 02-01 | Control Asm Bypass Hydro         |
| 28      | 532 17 57-65 | Rod, Parking Brake   | 96      | 532 12 47-88 | Spring, Retainer 1"              |
| 29      | 532 07 16-73 | Cap, Parking Brake   | 103     | 873 94 08-00 | Nut Hex Jam Toplock 1/2-20 UNF   |
| 30      | 532 17 49-73 | Bracket, Transmission  | 116     | 872 14 06-08 | Bolt 3/8-16 x 1                  |
| 32      | 874 76 05-12 | Bolt Hex 5/16-18 UNC x 3/4   | 120     | 873 90 06-00 | Nut Lock 3/8-16                  |
| 34      | 532 17 55-78 | Shaft, Foot Pedal  | 150     | 532 17 54-56 | Spacer Retainer                  |
| 35      | 532 12 01-83 | Bearing, Nylon   | 151     | 819 13 32-10 | Washer 13/32 x 2 x 10            |
| 36      | 819 21 16-16 | Washer   | 156     | 532 16 60-02 | Washer Srrted 5/16ID x 1.125     |
| 37      | 532 12 49-63 | Pin, Roll  | 158     | 532 16 55-89 | Bracket Shift Mount              |
| 38      | 532 17 91-14 | Pulley, Composite  | 159     | 532 18 39-00 | Hub Tapered Flange Shift Lt      |
| 39      | 874 76 06-48 | Bolt 3/8-16 x 3  | 161     | 872 14 04-06 | Bolt Rdhd Sqnk 1/4-20 x 3/4 Gr 5 |
| 41      | 532 17 55-56 | Keeper, Belt, Idler  | 162     | 873 68 04-00 | Nut Crownlock 1/4-20 Unc         |
| 47      | 532 12 77-83 | Pulley, Idler, V-Belt  | 163     | 874 78 04-16 | Bolt Hex Fin 1/4-20 Unc x 1 Gr 5 |
| 48      | 532 15 44-07 | Bellcrank Clutch Grnd Drustl   | 164     | 819 09 10-10 | Washer 5/8 x .281 x 10 Ga.       |
| 49      | 532 12 32-05 | Retainer, Belt   | 165     | 532 16 56-23 | Bracket Pivot Lever              |
| 50      | 872 11 06-12 | Bolt Carr Sh 3/8-16 x 1-1/2 Gr. 5  | 166     | 532 16 68-80 | Screw 5/16-18 x 5/8              |
| 51      | 873 68 06-00 | Nut  | 168     | 532 16 54-92 | Bolt Shoulder 5/16-18 x .561     |
| 52      | 873 68 05-00 | Nut Crownlock 5/16-28  | 169     | 532 16 55-80 | Plate Fastening Lt               |
| 53      | 532 10 57-10 | Link, Clutch   | 197     | 532 16 96-13 | Nyliner Snap-In                  |
| 55      | 532 10 57-09 | Spring, Return, Clutch   | 198     | 532 16 95-93 | Washer Nyliner                   |
| 56      | 817 06 06-20 | Screw 3/8-16 x 1-1/4   | 199     | 532 16 96-12 | Bolt Shoulder 5/16-18 UNC        |
| 57      | 532 14 02-94 | V-Belt, Drive  | 200     | 872 14 05-08 | Bolt RDHD SQNK 5/16-18 UNC x 1   |
| 59      | 532 16 96-91 | Keeper, Belt, Center   | 202     | 872 11 06-14 | Bolt Carr Sh 3/8-16 x 1-3/4 Gr.  |
| 61      | 817 12 06-14 | Screw 3/8-16 x .875  | 205     | 819 17 16-16 | Washer 17/32 x 1 x 16 Ga.        |
| 62      | 532 12 48-72 | Cover, Pedal   | 212     | 532 14 52-12 | Nut Hex Flange Lock              |
| 63      | 532 18 02-19 | Pulley, Engine   | 250     | 817 06 06-12 | Screw 3/8-16 x .75               |
| 64      | 871 17 07-64 | Bolt Hex 7/16 x 4 Gr. 5  | 263     | 817 00 06-12 | Screw Hex Wsh Thdr 3/8-16 x 3/4  |
| 65      | 810 04 07-00 | Washer   | 269     | 532 18 24-02 | Guard Muffler OHV B&S RH         |
| 66      | 532 15 47-78 | Keeper, Belt Engine F-proof  |         |              |                                  |
| 69      | 532 14 24-32 | Screw  |         |              |                                  |
| 70      | 532 18 02-18 | Guide, Belt, Mower Drive RH  |         |              |                                  |

**NOTE:** All component dimensions given in U.S. inches  
 1 inch = 25.4 mm



# REPAIR PARTS

TRACTOR- -MODEL NO. 12-107H (P12H107A), PRODUCT NO. 964 77 71-00  
STEERING ASSEMBLY

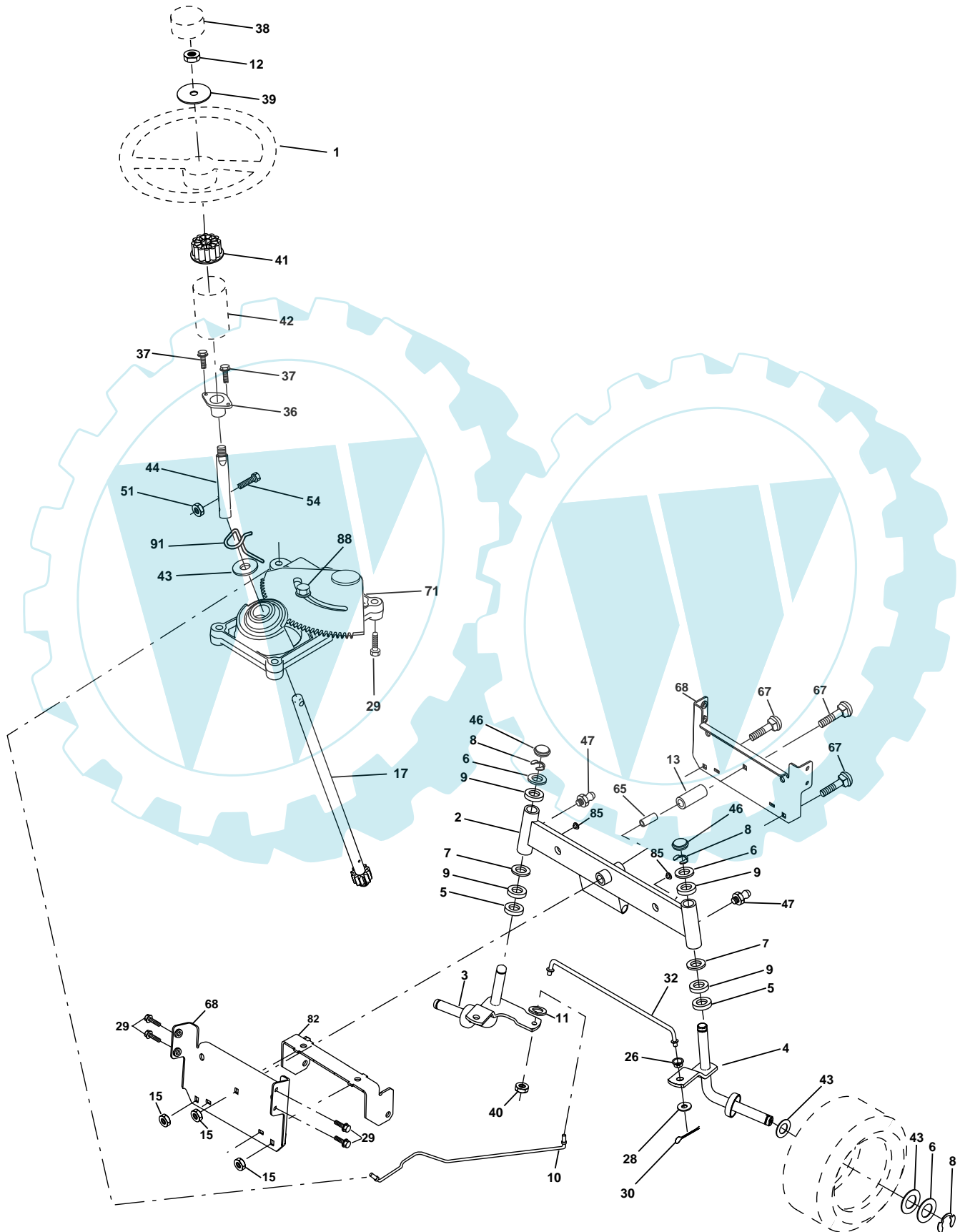

## REPAIR PARTS

TRACTOR- -MODEL NO. 12-107H (P12H107A), PRODUCT NO. 964 77 71-00  
STEERING ASSEMBLY

| KEY NO. | PART NO.     | DESCRIPTION                       |
|---------|--------------|-----------------------------------|
| 1       | 532 13 97-68 | Wheel Steering Opp. Sears Blk     |
| 2       | 532 17 51-31 | Axle Asm                          |
| 3       | 532 16 98-40 | Spindle Asm LH                    |
| 4       | 532 16 98-39 | Spindle Asm RH                    |
| 5       | 532 12 49-31 | Bearing Race Thrust Harden        |
| 6       | 532 12 17-48 | Washer 25/32 x 1-5/8 x 16 Ga      |
| 7       | 819 27 20-16 | Washer 27/32 x 1-1/4 x 16 Ga      |
| 8       | 812 00 00-29 | Ring Klip #t5304-75               |
| 9       | 532 12 49-37 | Bearing Col Strg Blk              |
| 10      | 532 17 51-21 | Link Drag                         |
| 11      | 810 04 06-00 | Washer Lock Hvy Hlcl Spr 3/8      |
| 12      | 873 94 08-00 | Nut Hex Jam Toplock 1/2-20 UNF    |
| 13      | 532 13 65-18 | Spacer Brace Axle                 |
| 15      | 532 14 52-12 | Nut Hexflange Lock                |
| 17      | 532 18 06-41 | Shaft Asm Strg                    |
| 26      | 532 12 68-47 | Bushing Link Drag Blk LR          |
| 28      | 819 13 14-16 | Washer 13/32 x 7/8 x 16 Ga        |
| 29      | 817 06 06-12 | Screw 3/8-16 x .75                |
| 30      | 876 02 04-12 | Pin Cotter 1/8 x 3/4 Cad          |
| 32      | 532 13 04-65 | Rod Tie Wire Form 19 75 Mech      |
| 36      | 532 15 50-99 | Bushing Strg Nat .623/.618ld      |
| 37      | 532 15 29-27 | Screw TT #10-32 x 5 x 3/8 Flange  |
| 38      | 532 14 01-75 | Cap Wheel Steer P/L               |
| 39      | 819 18 38-12 | Washer 19/16 ID x 2-3/8 OD 12 Ga. |
| 40      | 532 12 47-01 | Nut Lock Center 3/8-24unf         |
| 41      | 532 10 07-11 | Adaptor Wheel Strg                |
| 42      | 532 16 96-33 | Boot Shaft Steering               |
| 43      | 532 12 17-49 | Washer 25/32 X 1 1/4 X 16 Ga      |
| 44      | 532 18 06-40 | Extension Steering                |
| 46      | 532 12 12-32 | Cap Spindle Fr Top Blk            |
| 47      | 532 18 32-26 | Fitting Grease                    |
| 51      | 873 54 04-00 | Nut Crownlock 1/4-28              |
| 54      | 871 13 04-20 | Bolt Hex 1/4-28 UNF x 1-1/4 Gr. 8 |
| 65      | 532 16 03-67 | Spacer Brace Axle                 |
| 67      | 872 14 06-18 | Bolt RDHD SQ 3/8-16 UNC x 2-1/4   |
| 68      | 532 16 98-27 | Brace Axle                        |
| 71      | 532 17 51-46 | Steering Asm.                     |
| 82      | 532 16 98-35 | Bracket Susp. Chassis Front       |
| 85      | 532 13 38-35 | Fastener Christmas Tree           |
| 88      | 532 17 51-18 | Bolt Shoulder 7/16-20             |
| 91      | 532 17 55-53 | Clip Steering                     |

**NOTE:** All component dimensions given in U.S. inches.  
1 inch = 25.4 mm.

# REPAIR PARTS

TRACTOR- -MODEL NO. 12-107H (P12H107A), PRODUCT NO. 964 77 71-00  
SEAT ASSEMBLY

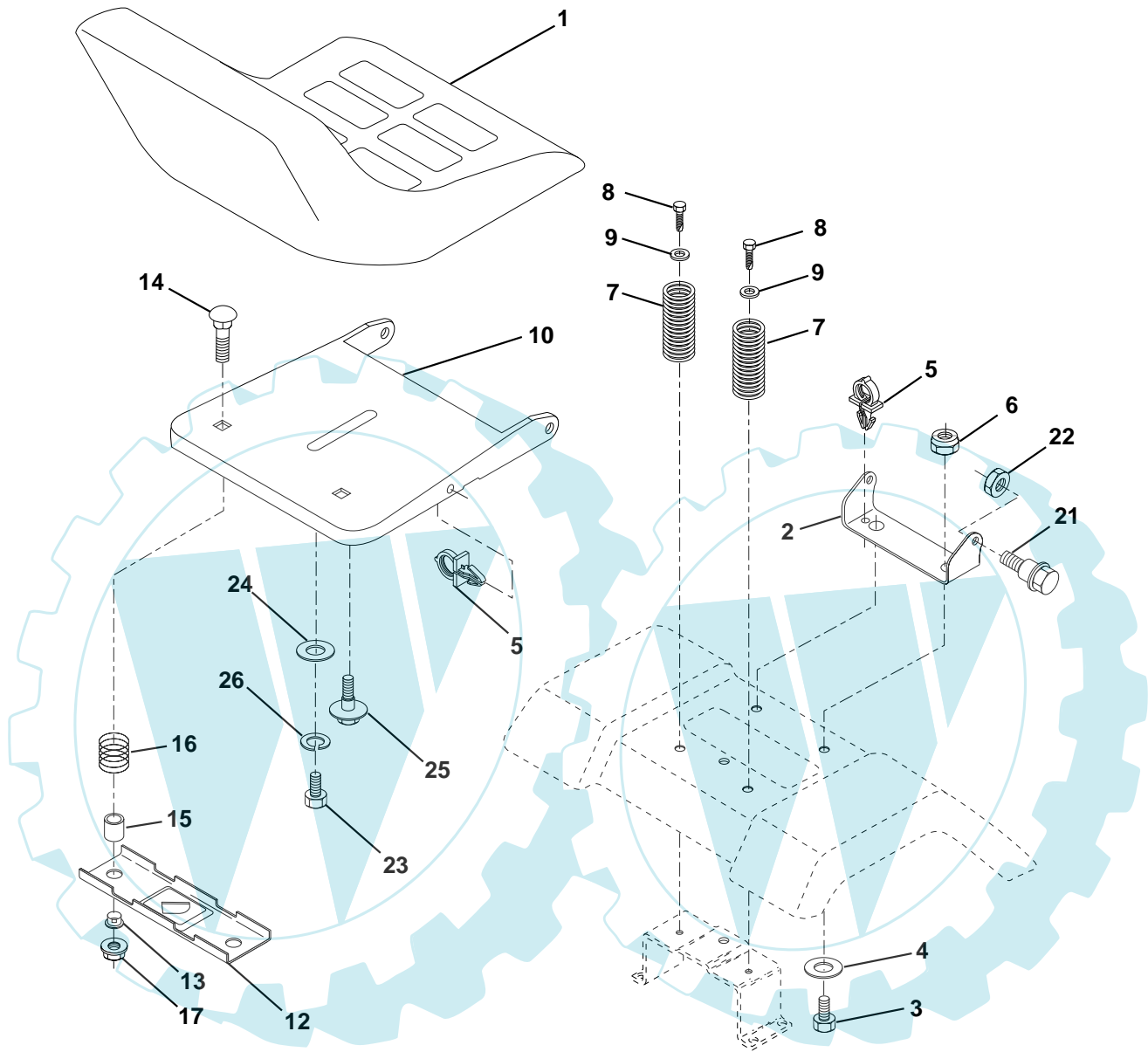

| KEY NO. | PART NO.     | DESCRIPTION                    |
|---------|--------------|--------------------------------|
| 1       | 532 14 01-16 | Seat                           |
| 2       | 532 14 05-51 | Bracket Pivot Seat 8 720       |
| 3       | 871 11 06-16 | Bolt Fin Hex 3/8-16unc X 1     |
| 4       | 819 13 16-10 | Washer 13/32 X 1 X 10 Ga       |
| 5       | 532 14 50-06 | Clip Push-In                   |
| 6       | 873 80 06-00 | Nut Lock Hex w/Wsh 3/8-16 Unc  |
| 7       | 532 12 41-81 | Spring Seat Cprsn 2 250 Blk Zi |
| 8       | 817 00 06-16 | Screw 3/8-16 X 1.5             |
| 9       | 819 13 16-14 | Washer 13/32 X 1 X 14 Ga.      |
| 10      | 532 18 24-93 | Pan Seat                       |
| 12      | 532 12 12-46 | Bracket Mounting Switch        |
| 13      | 532 12 12-48 | Bushing Snap Blk Nyl 50 Id     |
| 14      | 872 05 04-12 | Bolt Rdhd Sht Nk 1/4-20x1-1/2  |

| KEY NO. | PART NO.     | DESCRIPTION                       |
|---------|--------------|-----------------------------------|
| 15      | 532 13 43-00 | Spacer Split 28x 96 Yel Zinc      |
| 16      | 532 12 12-50 | Spring Cprsn 1 27 Blk Pnt         |
| 17      | 532 12 39-76 | Nut Lock 1/4 Lge Flg Gr 5 Zinc    |
| 21      | 532 17 18-52 | Bolt Shoulder 5/16-18 Unc -2A     |
| 22      | 873 80 05-00 | Nut Lock Hex W/Insert 5/16-18 UNC |
| 23      | 871 11 08-14 | Bolt Hex Black                    |
| 24      | 819 17 19-12 | Washer 17/32 X 1-3/16 X 12 Ga.    |
| 25      | 532 12 70-18 | Bolt Shoulder 5/16-18 X 62        |
| 26      | 810 04 08-00 | Washer Lock Hvy HLCLSPR 1/2       |

**NOTE:** All component dimensions given in U.S. inches.  
1 inch = 25.4 mm

# REPAIR PARTS

TRACTOR- -MODEL NO. 12-107H (P12H107A), PRODUCT NO. 964 77 71-00  
DECALS

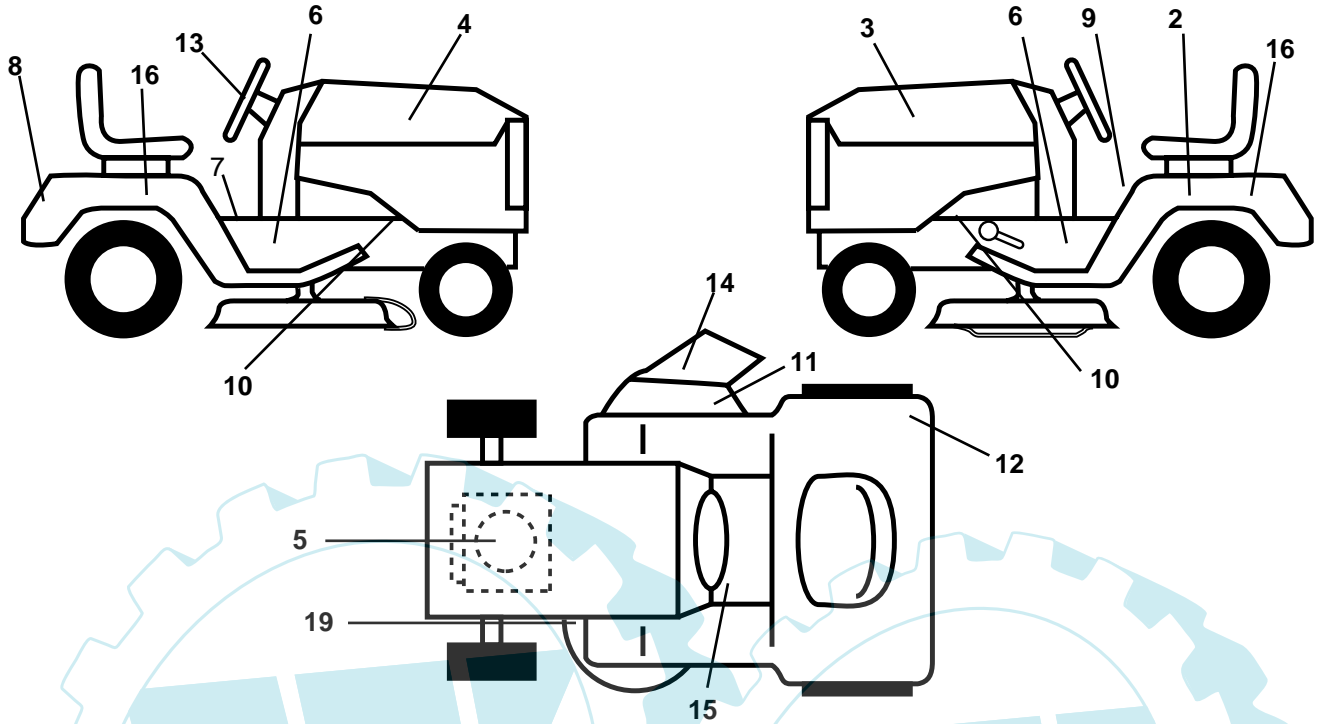

| KEY NO. | PART NO.     | DESCRIPTION                   |
|---------|--------------|-------------------------------|
| 2       | 532 14 50-05 | Decal Bat Dan/Poi P/L Symbols |
| 3       | 532 18 56-50 | Decal Hood LH                 |
| 4       | 532 18 56-49 | Decal Hood RH                 |
| 5       | 532 18 48-54 | Decal Engine                  |
| 6       | 532 18 56-51 | Decal Chas. Turbo Collection  |
| 7       | 532 14 08-37 | Decal Saddle Brake Parking    |
| 8       | 532 18 56-48 | Decal Fender                  |
| 9       | 532 14 54-98 | Decal Read Owners Manual Syms |
| 10      | 532 15 97-36 | Decal Chassis Hot Muffler     |
| 11      | 532 18 21-66 | Decal Mower Cut finger Symbol |
| 12      | 532 18 04-32 | Decal 100 DbA/Ce              |

| KEY NO. | PART NO.     | DESCRIPTION                     |
|---------|--------------|---------------------------------|
| 13      | 532 18 56-47 | Decal Strg Wheel Cap            |
| 14      | 532 17 91-28 | Decal Deck "B"                  |
| 15      | 532 15 97-37 | Decal Brake/Clutch              |
| 16      | 532 18 56-54 | Decal Fender Automatic          |
| 19      | 532 16 03-96 | Decal V-Belt Sch                |
| --      | 532 16 92-10 | Decal By-Pass                   |
| --      | 532 16 25-98 | Decal Drawbar Load Limit        |
| --      | 532 13 83-11 | Decal Lift Handle (Lift Handle) |
| --      | 532 18 52-36 | Manual Operator's Euro          |
| --      | 532 18 52-37 | Manual Operator's Scan          |

## WHEELS & TIRES

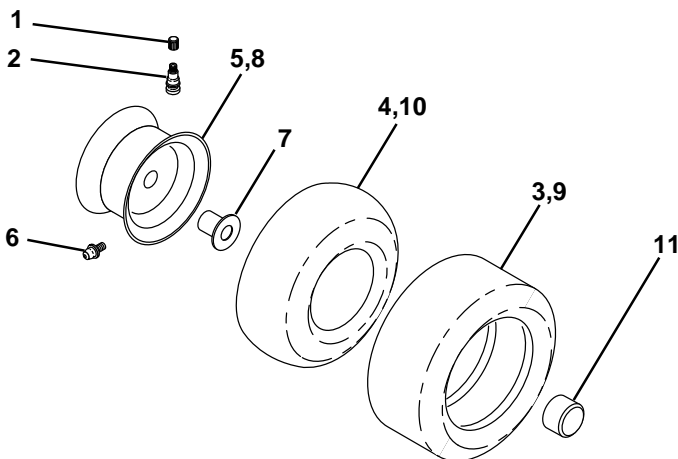

| KEY NO. | PART NO.     | DESCRIPTION                       |
|---------|--------------|-----------------------------------|
| 1       | 532 05 91-92 | Cap Valve Tire                    |
| 2       | 532 06 51-39 | Stem Valve                        |
| 3       | 532 10 62-22 | Tire F Ts 15 X 6 0 - 6 Service    |
| 4       | 532 05 99-04 | Tube Front (Service Item Only)    |
| 5       | 532 12 51-21 | Rim Asm 6" front Yellow Service   |
| 6       | 532 12 49-57 | Fitting Grease (Front Wheel Only) |
| 7       | 532 12 49-59 | Bearing Flange (Front Wheel Only) |
| 8       | 532 12 51-22 | Rim Asm 8" rear Yellow Service    |
| 9       | 532 10 62-68 | Tire R Ts 18 x 9.5-8 C. Service   |
| 10      | 532 12 49-26 | Tube Rear (Service Item Only)     |
| 11      | 532 17 50-39 | Cap Axle Blk 1 50 X 1 00          |

**NOTE:** All component dimensions given in U.S. inches  
1 inch = 25.4 mm

# REPAIR PARTS

TRACTOR- -MODEL NO. 12-107H (P12H107A), PRODUCT NO. 964 77 71-00  
ENGINE

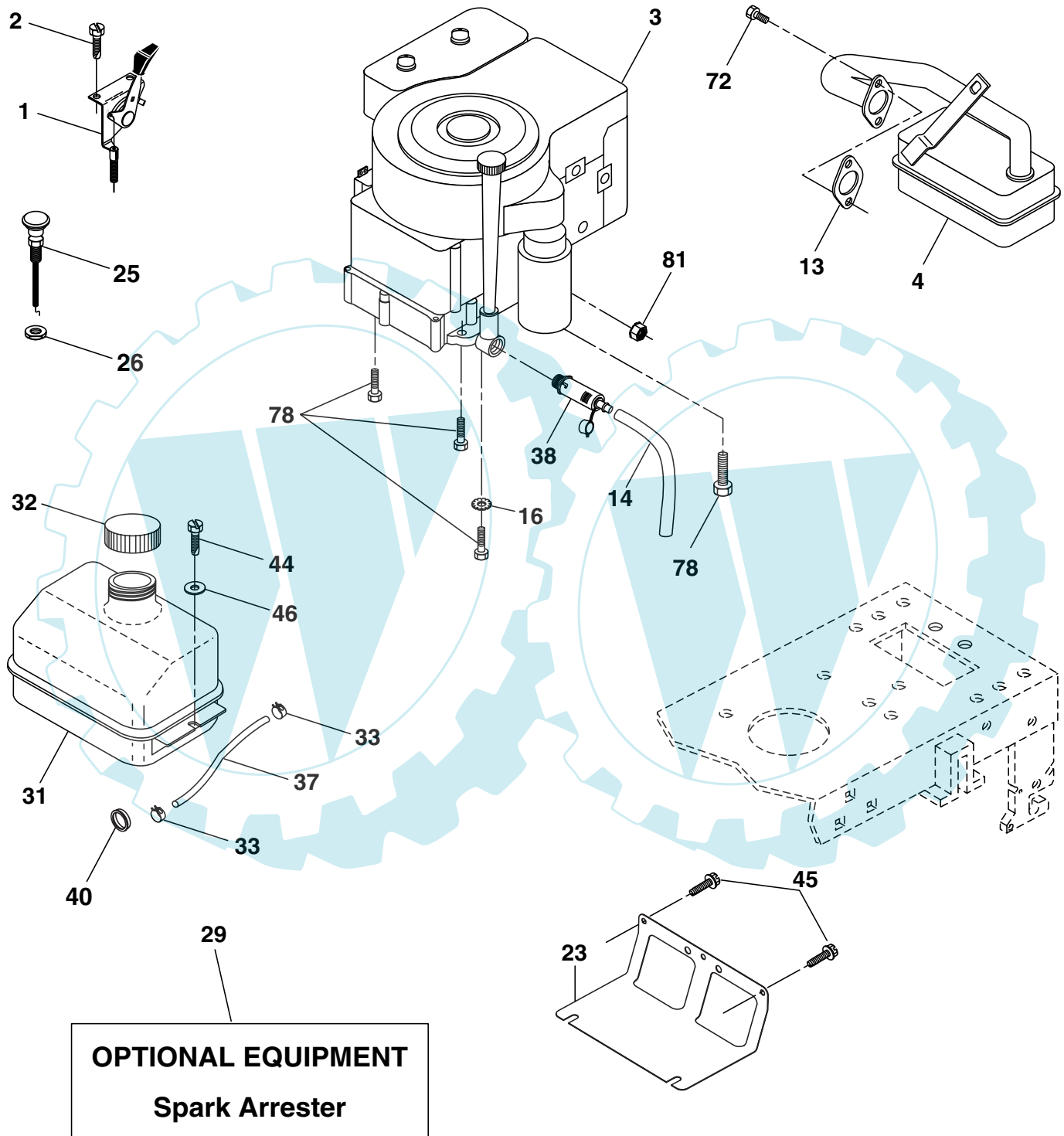

## REPAIR PARTS

TRACTOR- -MODEL NO. 12-107H (P12H107A), PRODUCT NO. 964 77 71-00  
ENGINE

| KEY NO. | PART NO.     | DESCRIPTION   |
|---------|--------------|---|
| 1       | 532 17 05-51 | Control Th/ch Flag Eec  |
| 2       | 817 72 04-08 | Screw Hex Thd Cut 1/4-20 x 1/2  |
| 3       | -----        | Engine B&S Model No. 21A807<br>(Order parts from engine manufacturer) |
| 4       | 532 17 97-58 | Muffler LT B&S 12/12 5 HP   |
| 13      | 532 16 52-91 | Gasket Eng  |
| 14      | 532 14 84-56 | Tube Drain Oil Easy   |
| 16      | 811 05 06-00 | Washer Lock Ext Tooth 3/8   |
| 23      | 532 16 98-37 | Shield Brn/Dbr Guard  |
| 25      | 532 18 09-45 | Control Choke   |
| 26      | 873 92 06-00 | Nut Keps 3/8-24 UNF   |
| 29      | 532 13 71-80 | Kit Spark Arrecter  |
| 31      | 532 18 49-00 | Tank Fuel Front 1.25  |
| 32      | 532 14 05-27 | Cap Asm Fuel W/sym Vented   |
| 33      | 532 12 34-87 | Clamp Hose Blk  |
| 37      | 532 13 70-40 | Line Fuel 20"   |
| 38      | 532 18 16-54 | Plug Drain Oil Easy   |
| 40      | 532 12 40-28 | Bushing Snap Nyl Blk Fuel Line  |
| 44      | 817 67 04-12 | Screw Hexwsh Thdrol 1/4-20 x 3/4                                      |
| 45      | 817 00 06-12 | Screw Hexwsh Thdrol 3/8-16 x 3/4                                      |
| 46      | 819 09 14-16 | Washer 9/32 x 7/8 x 16 Ga.  |
| 72      | 532 18 39-06 | Screw Socket Head 5/16-18 x 1   |
| 78      | 817 06 06-20 | Screw 3/8-16 x 1-1/4  |
| 81      | 873 51 04-00 | Nut Keps Hex 1/4-20 UNC   |

**NOTE:** All component dimensions given in U.S. inches  
1 inch = 25.4 mm

# REPAIR PARTS

TRACTOR- -MODEL NO. 12-107H (P12H107A), PRODUCT NO. 964 77 71-00  
MOWER LIFT

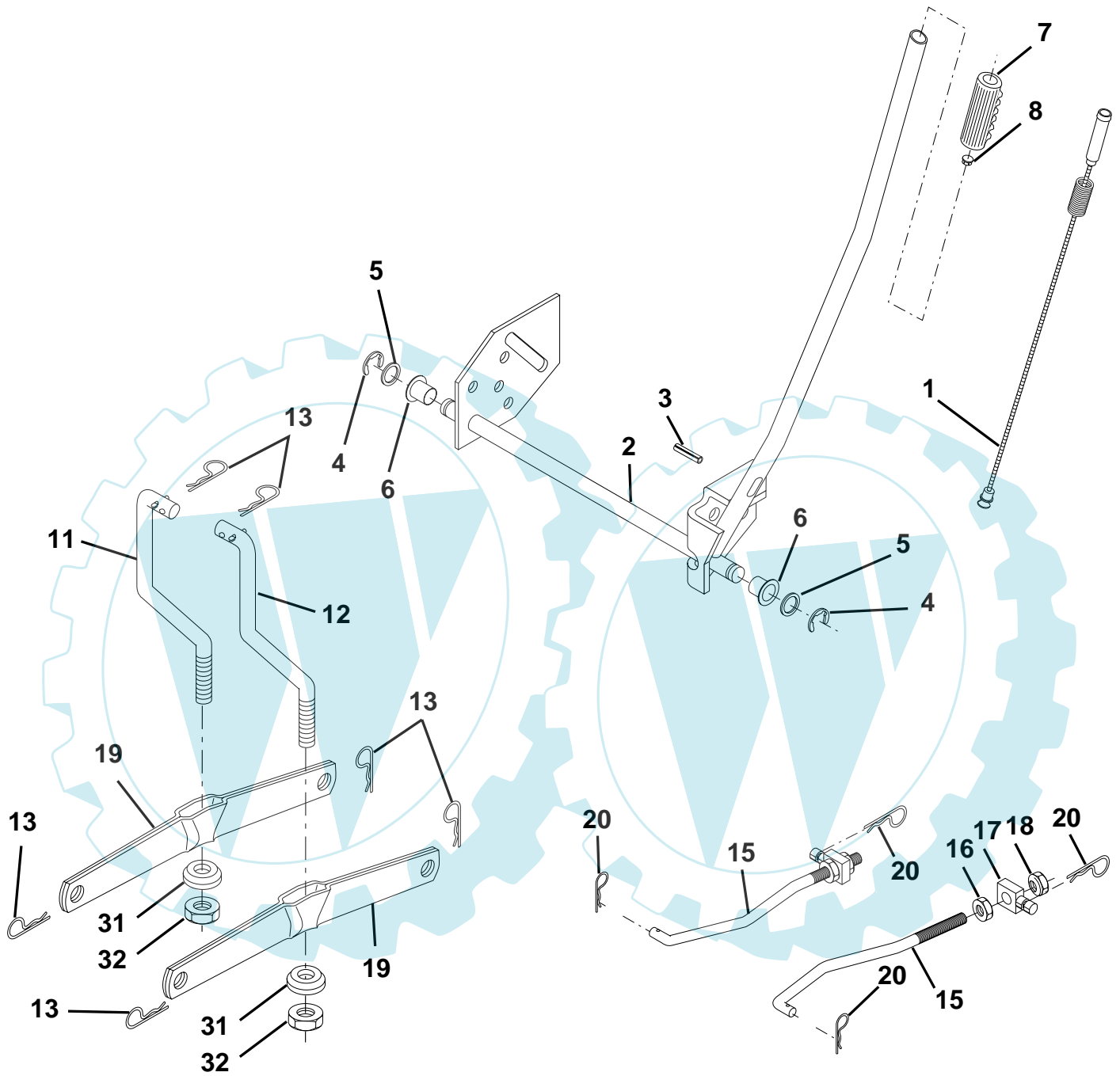

## REPAIR PARTS

TRACTOR- -MODEL NO. 12-107H (P12H107A), PRODUCT NO. 964 77 71-00  
MOWER LIFT

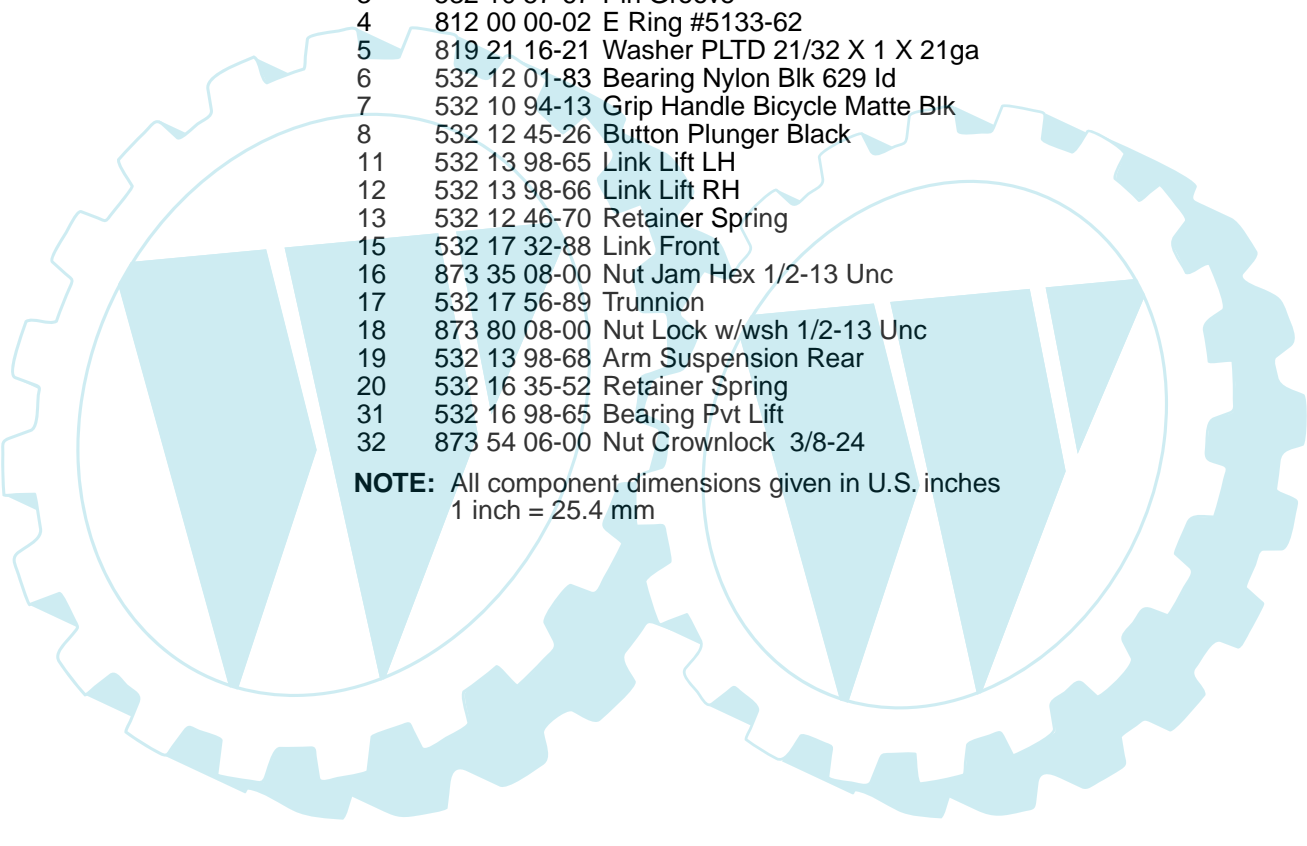

| KEY NO. | PART NO.     | DESCRIPTION                   |
|---------|--------------|-------------------------------|
| 1       | 532 15 94-60 | Wire Asm Inner W/Plunger      |
| 2       | 532 15 94-71 | Shaft Asm Lift                |
| 3       | 532 10 57-67 | Pin Groove                    |
| 4       | 812 00 00-02 | E Ring #5133-62               |
| 5       | 819 21 16-21 | Washer PLTD 21/32 X 1 X 21ga  |
| 6       | 532 12 01-83 | Bearing Nylon Blk 629 Id      |
| 7       | 532 10 94-13 | Grip Handle Bicycle Matte Blk |
| 8       | 532 12 45-26 | Button Plunger Black          |
| 11      | 532 13 98-65 | Link Lift LH                  |
| 12      | 532 13 98-66 | Link Lift RH                  |
| 13      | 532 12 46-70 | Retainer Spring               |
| 15      | 532 17 32-88 | Link Front                    |
| 16      | 873 35 08-00 | Nut Jam Hex 1/2-13 Unc        |
| 17      | 532 17 56-89 | Trunnion                      |
| 18      | 873 80 08-00 | Nut Lock w/wsh 1/2-13 Unc     |
| 19      | 532 13 98-68 | Arm Suspension Rear           |
| 20      | 532 16 35-52 | Retainer Spring               |
| 31      | 532 16 98-65 | Bearing Pvt Lift              |
| 32      | 873 54 06-00 | Nut Crownlock 3/8-24          |

**NOTE:** All component dimensions given in U.S. inches  
1 inch = 25.4 mm



**REPAIR PARTS**

**TRACTOR- -MODEL NO. 12-107H (P12H107A), PRODUCT NO. 964 77 71-00  
MOWER**

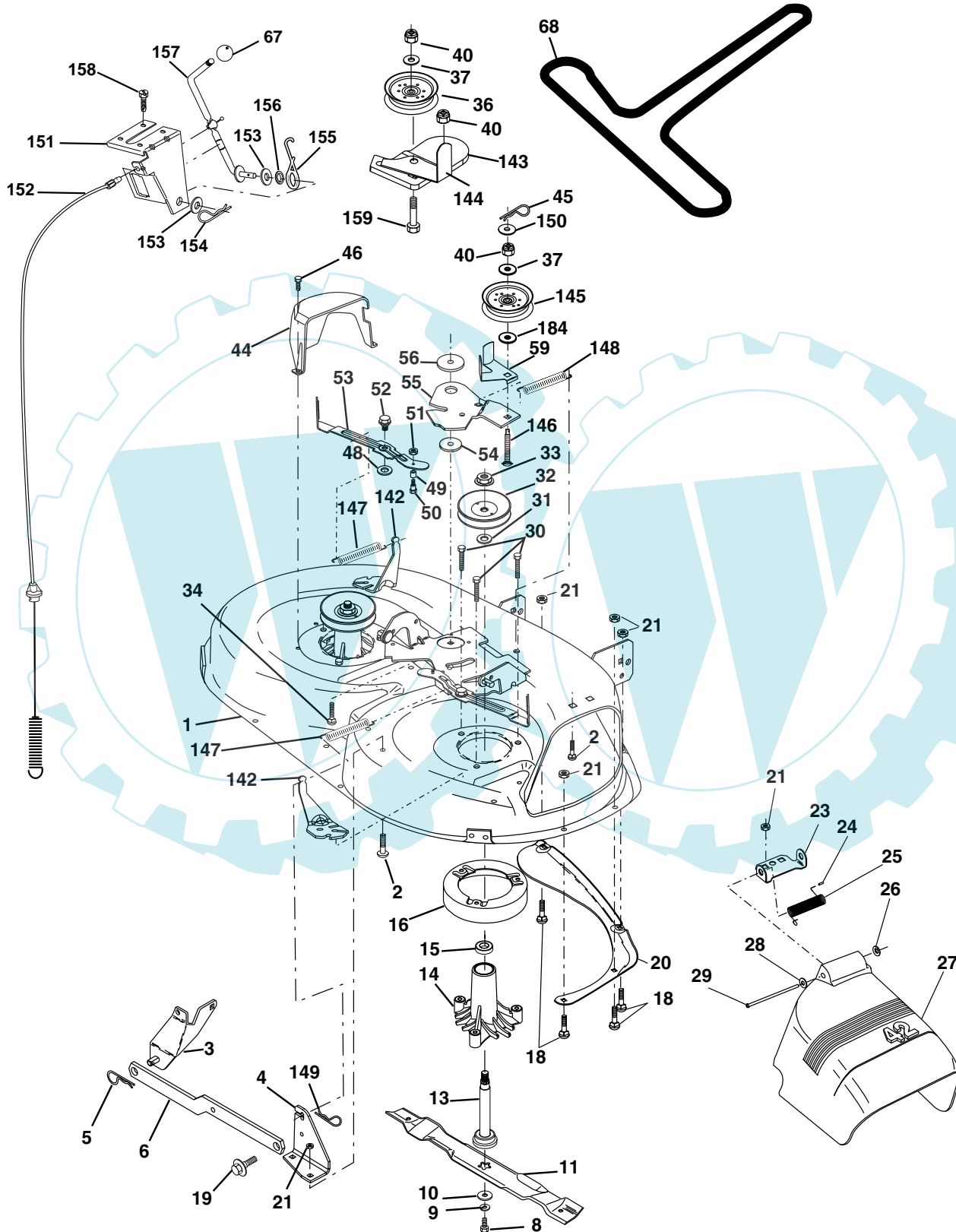

# REPAIR PARTS

**TRACTOR- -MODEL NO. 12-107H (P12H107A), PRODUCT NO. 964 77 71-00  
MOWER**

| KEY NO. | PART NO.     | DESCRIPTION                     | KEY NO. | PART NO.     | DESCRIPTION  |
|---------|--------------|---------------------------------|---------|--------------|--|
| 1       | 532 16 58-92 | Housing Asm Mower 42" T-Path    | 49      | 532 17 42-84 | Roller Asm Cam Follower 42" dec  |
| 2       | 872 14 05-06 | Bolt Rdhd Sqnk 5/16-18unc X3/4  | 50      | 532 13 13-40 | Bolt Shldr 10-24 Zinc Gr 5 42"   |
| 3       | 532 13 80-17 | Bracket Asm Fr Sway Bar 38/42   | 51      | 532 06 91-80 | Nut Lock #10-24 Unc  |
| 4       | 532 16 54-60 | Bracket Asm Deck 42" sway Bar   | 52      | 532 13 98-88 | Bolt Shoulder 5/16-18 Unc Blkz   |
| 5       | 532 12 46-70 | Retainer Spring                 | 53      | 532 13 18-45 | Arm Asm Pad Brake  |
| 6       | 532 17 80-24 | Bar Sway Deck                   | 54      | 532 17 85-15 | Washer Hardened  |
| 8       | 532 85 08-57 | Bolt 3/8 - 24 X 1.25 Gr 8       | 55      | 532 15 50-46 | Arm Idler 42" mower LT/YT  |
| 9       | 810 03 06-00 | Washer Lock Hvy 3/8 Unplated    | 56      | 532 16 57-23 | Spacer Retainer Pm Mower   |
| 10      | 532 14 02-96 | Washer Hard Blade Mower         | 59      | 532 14 10-43 | Guard TUV Idler  |
| 11      | 532 13 89-71 | Blade Mower High Lift           | 67      | 532 10 69-32 | Knob Rd 3/8-16 Plstc Thds Blk  |
| 13      | 532 13 76-45 | Shaft Asm W/Lower Bearing       | 68      | 532 18 02-15 | V-Belt Mower   |
| 14      | 532 12 87-74 | Housing Mandrel Vented (Machd)  | 142     | 532 16 58-90 | Arm Spring Brake Mower   |
| 15      | 532 11 04-85 | Bearing Ball Mandrel            | 143     | 532 15 71-09 | Bracket Arm Idler 42"  |
| 16      | 532 17 44-93 | Stripper Round Mower            | 144     | 532 15 86-34 | Keeper Belt 42" Clutch Cable   |
| 18      | 872 14 05-05 | Bolt Carr 5/16-18 X 5/8         | 145     | 532 16 58-88 | Pulley Idler Flat  |
| 19      | 532 13 28-27 | Bolt Shoulder                   | 146     | 532 17 19-77 | Bolt Carriage Idler  |
| 20      | 532 15 97-70 | Baffle Vortex 42"               | 147     | 532 17 97-48 | Spring Extension   |
| 21      | 873 68 05-00 | Nut Crown Lock 5/16-18          | 148     | 532 16 90-22 | Spring Return Idler  |
| 23      | 532 17 75-63 | Bracket Deflector Mower 42"     | 149     | 532 16 58-98 | Retainer Spring Yellow   |
| 24      | 532 10 53-04 | Cap Sleeve 80x 112 Blk Mower    | 150     | 819 09 12-16 | Washer 9/32 x 3/4 x 16 Ga.   |
| 25      | 532 12 37-13 | Spring Torsion Deflector 2 52   | 151     | 532 16 96-70 | Bracket Clutch Cable   |
| 26      | 532 11 04-52 | Nut Push Phos & Oil             | 152     | 532 18 15-55 | Clutch Cable 42"   |
| 27      | 532 17 18-59 | Shield Deflector Mower 42"      | 153     | 532 16 96-74 | Washer Flat 3/8" Type B  |
| 28      | 819 11 10-16 | Washer 11/32 X 5/8 X 16 Ga.     | 154     | 532 16 96-75 | Spring Retainer  |
| 29      | 532 13 14-91 | Rod Hinge 42" 6 75 Wlg          | 155     | 532 16 96-71 | Spring Retention Lvr Cltch Cab   |
| 30      | 532 17 39-84 | Screw Thdrol                    | 156     | 532 16 96-72 | Spacer Clutch Cable  |
| 31      | 532 12 99-63 | Washer Spacer Mower Vented      | 157     | 532 16 96-69 | Rod Clutch Cable 3/8"  |
| 32      | 532 15 35-35 | Pulley Mandrel 42/44/50         | 158     | 817 72 04-08 | Screw Hex Thd Cut 1/4-20 x 1/2   |
| 33      | 532 17 83-42 | Nut Flng Top Lock               | 159     | 872 14 06-14 | Bolt Rdhd Sqnk 3/8-16 UNC x 1-3/4  |
| 34      | 872 11 06-14 | Bolt Rdhd 3/8-16unc X 1-3/4 Gr5 | 184     | 819 13 14-10 | Washer 13/32 x 7/8 x 10 Ga.  |
| 36      | 532 13 14-94 | Pulley Idler Flat 3 060         | --      | 532 18 19-25 | Replacement Mower, Complete  |
| 37      | 819 13 13-16 | Washer 13/32 X 13/16 X 16       | --      | 532 13 07-94 | Mandrel Assembly (Includes Housing, Shaft and Shaft Hardware Only - Pulley Not Included) |
| 40      | 873 68 06-00 | Nut, Crownlock 3/8-16 UNC       |         |              |  |
| 44      | 532 14 00-88 | Guard Mandrel LH Black          |         |              |  |
| 45      | 532 12 47-88 | Spring Retainer 1" Zinc/cad     |         |              |  |
| 46      | 532 13 77-29 | Screw Hex Thd Cut 1/4-20x5/8 T  |         |              |  |
| 48      | 532 13 39-44 | Washer Hardened Smaller         |         |              |  |

**NOTE:** All component dimensions given in U.S. inches  
1 inch = 25.4 mm